

KODAK Solar Module

xxxW FBBI AM

xxxW FBBI AM+

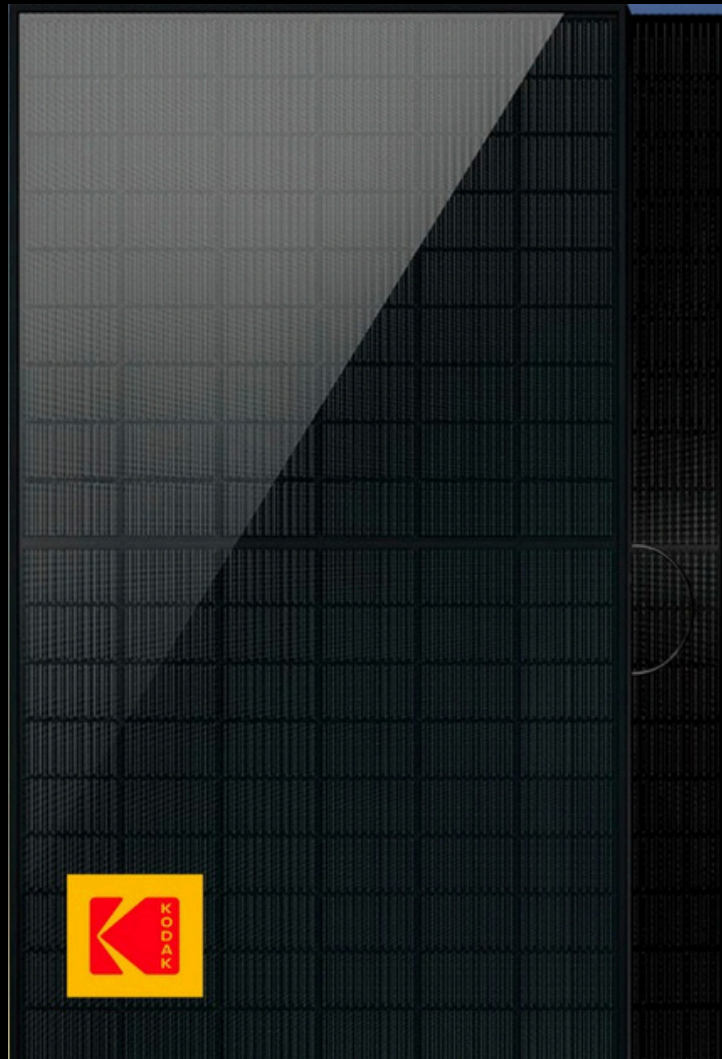

Installation Manual

Please read this manual carefully before installing and using the solar module

Please keep this manual with you for future reference

Content

1. General information	1
2. Safety precautions	1
3. Storage and unpacking	1
4. Product identification	2
5. Mechanical installation	2
5.1 Climate condition	2
5.2 Site selection	2
5.3 Module tilt angle	3
5.4 Installation methods	3
6. Electrical installation	5
6.1 Module wiring	5
6.2 Grouding	6
6.3 Inverters configuration	7
7. Maintenance	8
8. Disclaimer of liability	9



1. General information

This manual contains information regarding the installation and safe handling of KODAK photovoltaic modules. Installers should read this manual carefully and follow the instructions strictly prior to installing the modules. Failure to follow these instructions may result in death, bodily injury or damage to property. The installation of modules requires specialized skills and should only be performed by qualified, licensed professionals. If you have any questions about installation, please contact us for further information.

2. Safety precautions

Kodak modules have passed all required safety tests according to the IEC 61730 and are rated with Application Class A, and within this application class modules are considered to meet the requirements for Safety Class II. All installations must be performed in compliance with all local and national applicable standards, codes and regulations.

Installers should assume all risks of injury that might occur during installation, including, but not limited to, the risk of electric shock.

Do not use mirrors or other magnifiers to artificially concentrate sunlight on the modules.

Do not attempt to disassemble the modules or remove any components from the modules.

Do not install the module in the rain, snow or in windy conditions.

Use electrical insulated tools and appropriate protective equipment to reduce risk of electric shock.

Cover the module with an opaque material during installation to keep electricity from being generated.

Do not disconnect under load.

3. Storage and unpacking

Store modules in a dry and ventilated room.

Do not stack packing cartons more than two layers high.

Unpack module pallets with care and follow the unpacking steps. Be careful when unpacking, transporting and storing the modules.

Do not lift the module by grasping the module's junction box or electrical leads.

Do not place modules on top of each other.

Do not stand or step on the module.



Do not drop the module or allow objects to fall on the module.

Do not leave the module unsupported or unsecured.

Keep all electrical contacts clean and dry.

4. Product identification

Each KODAK module has two identical barcodes with 15 digits for its unique identification (one is in the laminate, and the second is on the backsheet).

A nameplate is affixed on the backside of the module. This nameplate describes main characteristics of the module, which include the product type, maximum power, open circuit voltage, short circuit current, maximum power voltage, maximum power current, all as measured under standard test conditions; maximum system voltage, weight, dimensions etc.. Do not remove any labels from the module. If the label was moved out, the module will void the warranty.

5. Mechanical installation

5.1 Climate condition

KODAK modules should be installed in the following conditions:

Ambient temperature: -20°C to +40°C

Operating temperature: -40°C to +85°C

Storage temperature: -40°C to +40°C

Humidity: below 85RH%

Wind load: below 2400Pa

Snow load: below 5400Pa

5.2 Site selection

KODAK modules should be installed in a location where they will receive maximum sunlight throughout the year. In the northern hemisphere, the modules should typically face south, and in the southern hemisphere, the modules should typically face north.

When choosing a site, avoid trees, buildings or obstructions, which could cast shadows on the modules especially during the winter months when the arc of the sun is lowest over the horizon. Shading causes loss of output, even though bypass diodes have been fitted in the junction box of the module to minimize any such loss.

KODAK modules have a Class C fire resistance rating in accordance with IEC61730-2 standard. For roof installation, modules should be mounted over a fire resistant covering, with adequate ventilation between the module backsheet and the mounting surface. In order to



maintain the fire class rating, the distance between the modules frame and the roof surface shall be at least 100mm.

Do not install the module near naked flame or flammable materials.

Do not install the module in a location where it would be immersed in water or continually exposed to water from a sprinkler or fountain etc.

5.3 Module tilt angle

Modules connected in series should be installed at same orientation and angle. Different orientation or angle may cause loss of output power due to difference of amount of sunlight exposed to the module.

Modules produce the most power when they are pointed directly at the sun. For installations where the modules are attached to a permanent structure, the modules should be tilted for optimum winter performance. As a rule, if the system power production is adequate in winter, it will be satisfactory during the rest of the year. Optimal tilting of the module is roughly the same as the latitude of installation location.

5.4 Installation methods

The modules can be installed on the frame using screw mounting and clamp mounting methods (as shown in Fig.1).

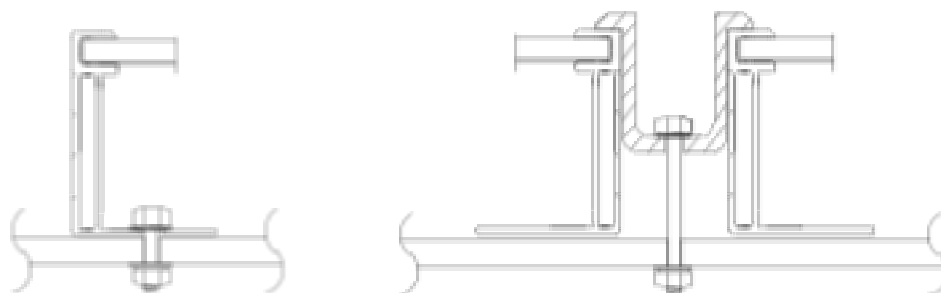

(a) Screw mounting (b) Clamp mounting

Fig.1 The module installed with (a) screw mounting, (b) clamp mounting

(a) Screw mounting

The frame of each module has eight mounting holes used to secure the modules to the support structure. If the wind or snow load is less than 2400Pa, you can use the four symmetry holes close to the inner side on module frame (as shown in Fig.2). If the wind or snow load exceeds 2400Pa, you must use all the eight mounting holes. The module frame must be attached to a mounting rail using M8 corrosion-proof screws together with spring washers and flat washers in eight symmetrical locations on the module. The applied torque should be 16~20 N.m(140-180 lbf.in.).



(b) Clamp mounting

The modules can be installed in both landscape (clamping on the short frame) and portrait (clamping on the long frame) modes by clamp mounting.

The module clamps should not come into contact with the front glass and must not deform the frame.

Be sure to avoid shadowing effects from the module clamps.

The module frame is not to be modified under any circumstances.

For detailed screw mounting and clamp mounting methods, please refer to the following table.

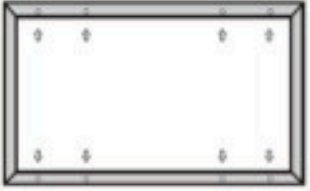
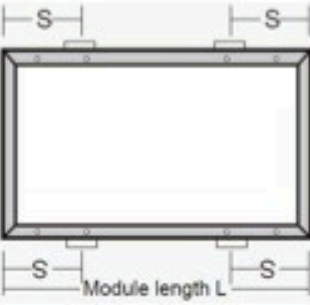
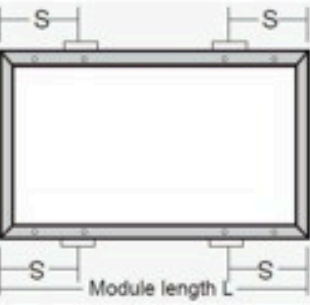
Loads	Wind Loads: 2400Pa Snow Loads: 2400Pa	Wind Loads: 2400Pa Snow Loads: 5400Pa
Screw mounting	<p>Using 4 mounting holes</p>  <p>○ Mounting holes</p>	<p>Using 8 mounting holes</p>  <p>○ Mounting holes</p>
Clamp mounting on long frames	<p>$0 < S < 1/4L$ (L: Module length)</p>  <p>▭ Permissible Clamp Range</p>	<p>$1/4L - 50\text{mm} < S < 1/4L + 50\text{mm}$</p>  <p>▭ Permissible Clamp Range</p>



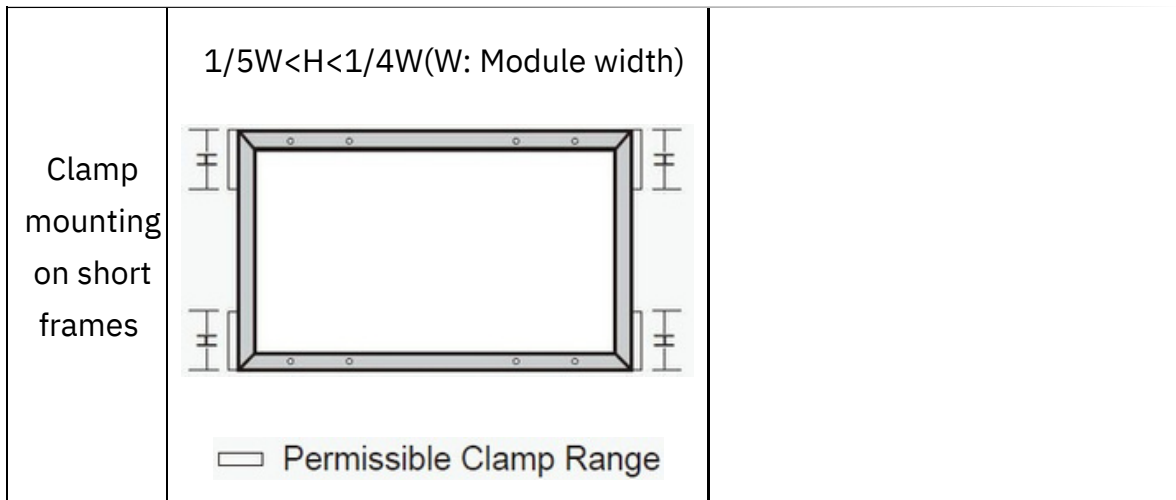

6. Electrical installation

6.1 Module wiring

Modules are supplied with cables and connectors to be used for system electrical connections. It is not recommended to use modules with different configurations and electrical characteristics in the same system. Modules can be connected in series to obtain a high operating voltage. The system voltage is equal to the sum of the voltage of each module. Modules can also be connected in parallel to obtain a high operating current. The system current is equal to the sum of the current of each string of modules. Under normal conditions, a module is likely to experience conditions that produce more current and/or voltage than reported at standard test conditions. The suggested fuse must be used for overcurrent protection. Accordingly, the values of I_{sc} and V_{oc} marked on this module should be multiplied by a factor of 1.25 when determining component voltage ratings, conductor ampacities, fuse sizes, and size of controls connected to the PV output. The maximum number of series connected modules depends on system design, the type of inverter used and environmental conditions. It should be noted that modules must not be connected together to create a voltage higher than the permitted system voltage. There is no limitation on the number of modules that can be connected in parallel; the number of modules is determined by system design parameters such as current or power output. The maximum number of modules to be installed in series on the installation, $N(\max)$, is calculated using the following formula:

$$N_{\max} = \frac{V_{\max, \text{system}}}{V_{oc}(STC)}$$



The maximum voltage supported on an installation (V_{max} . System), with KODAK's photovoltaic modules, is presented in the following table:

	IEC	UL
Maximum System Voltage (V)	1000/1500	1000/1500

6.2 Grounding

Grounding modules is necessary to reduce or eliminate shock and fire hazards. All module frames and mounting racks must be properly grounded in accordance with local and national electrical codes. Proper grounding is achieved by connecting the module frames and mounting racks continuously using a suitable grounding conductor. The grounding conductor or strap may be copper, copper alloy, or other material acceptable for use as an electrical conductor.

(a) Grounding by using grounded clamp

There are two grounding holes with 4.0 mm diameter in the middle of the long frames of the modules. The grounding between modules must be approved by qualified electrician. And the grounding device must be produced by qualified electrical manufacture. The recommended twist torque value is 2.3 N.m. A copper core in size of 12 AWG can be used as grounding clamp. The copper wire should not be compressed during the installation.

Note: The figure above is using TYCO. 1954381-1 (recommended)

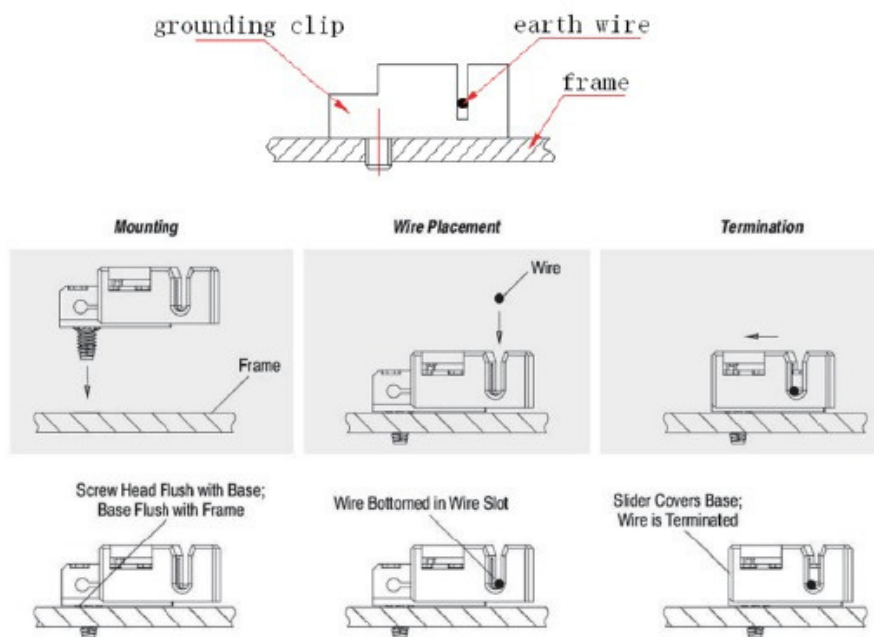

Fig.2 Grounding method (a)



(b) Grounding by using unused grounding hole

The existing grounding holes which have not been used can be used for grounding.

- 1) Direct the grounding clamp to the mounting hole on the frame. Thread the grounding clamp and the frame with grounding bolt.
- 2) Put the toothed gasket into the other side, then tighten and lock the nut. The recommended torque of locking the nut is 2.0 N.m ~2.2 N.m.
- 3) Thread the grounding clamp with grounding wire. The material and size of grounding wire should meet the relevant requirements of the national, regional and local rule, law and standard.
- 4) Finish the mounting with tightening the binding bolt of the grounding wire.

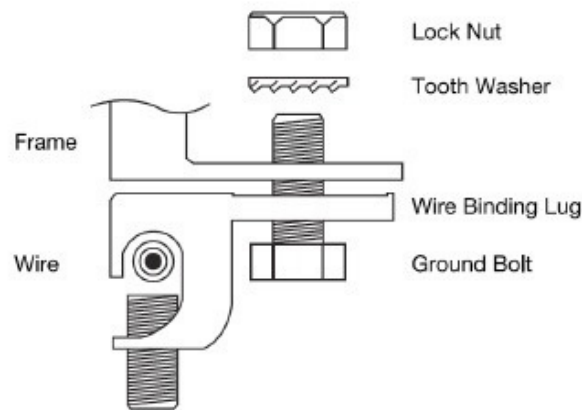

Fig.3 Grounding method (b)

(c) Additional third-party grounding devices

The modules can be grounded using third party grounding devices so long as they are certified for grounding modules and the devices are installed according to the manufacturer's specified instructions.

6.3 Inverters configuration

When installed in PV systems, Amerisolar modules normally do not need to be connected to earth and therefore can be operated together with either galvanically isolated (with transformer) and transformerless inverters. However, if the system is located in a hot, humid climate and the maximum voltage is greater than 600Vdc, then galvanically isolated inverters incorporating a transformer are recommended to be used and the negative pole of the array should be connected to earth.



7. Maintenance

In order to ensure optimum performance of the modules, it is required to perform regular inspection and maintenance of the modules. The following maintenance measures are recommended to be performed.

7.1 Visual Inspection

Perform a comprehensive inspection for the modules every six months.

Check whether there are visual defects in the components of the modules.

Check whether the front side of the modules is shaded by vegetation and other foreign

materials, and trim the vegetation and remove other foreign materials when shading on modules occurs.

Check whether mounting hardware is properly tightened, and adjust and tighten as necessary.

In the event that the tempered glass of modules is broken, the affected modules need to be replaced. Only qualified professionals can perform the replacement of modules.

Do not try to change the components of modules (Junction box, bypass diode and connector).

7.2 Connector and cable Inspection

Check the electrical connections between connectors and cables to make sure that all

connections are tight, secure, intact and free of corrosion.

Check the torque of terminal bolts at least once a year, and tighten them as necessary.

In the event that the connectors and cables are damaged, the damaged parts need to be replaced by qualified professionals.

7.3 Cleaning

Dirt and dust may accumulate on the glass surface of the modules and reduce the power output of the modules. It is recommended to clean the modules regularly to ensure maximum power output, especially in low rainfall areas.

In order to reduce the potential for electrical and thermal shock, the modules should be cleaned during early morning or late afternoon when solar radiation is low and the modules are cooler, especially in regions with high temperatures.

Use a soft sponge or cloth together with a mild detergent and clean water when cleaning the modules. Take care to avoid severe thermal shocks which may damage the modules by using water which has a similar temperature with the modules being cleaned.



It is not allowed to use metal tools such as blades, knives, steel wool and other abrasive materials.

For greasy dirt or other substances on the surface of the modules which are difficult to clean, conventional household glass cleaning agents can be used. Do not use the alkaline and strong acid solvents which may cause corrosion of glass.

The pressure of the cleaning water should be less than 690KPa. It is not recommended to use water with high mineral content as it may deposit on the glass surface when the water is dry. Most municipal water is suitable to clean the modules.

Do not use steam or corrosive chemicals to speed up the cleaning.

Do not try to clean broken glass or modules with broken lines or exposed wires, as it may cause electric shock.

When cleaning the modules, do not step on the modules; do not spray water on the backside of the modules or the cables; do not clean the backside of the modules; keep the connectors clean and dry; prevent fire and electrical shock.

KODAK modules are designed to be able to withstand high snow pressure. If you need to clear snow to improve output power of the modules, use a hair brush to gently remove the snow, and use the gas to blow the snow too. Do not try to remove frozen snow or ice on the modules which may cause damage to the modules.

8. Disclaimer of liability

Because the use of this manual and the conditions or methods of installation, operation, use and maintenance of the product are beyond KODAK's control, KODAK does not accept responsibility and expressly disclaims liability for loss, damage, or expense arising out of or in any way connected with such installation, operation, use or maintenance.

No responsibility is assumed by KODAK for any infringement of patents or other rights of third parties, which may result from use of the product. No license is granted by implication or otherwise under any patent or patent rights.

The information included in this manual is based on KODAK's knowledge and experience and is believed to be reliable; but such information including product specification (without limitations) and suggestions do not constitute a warranty, expresses or implied. KODAK reserves the right to change the manual.



Tips: Please read the instructions carefully before use



C E FCC RoHS 

MADE IN CHINA

www.kodak.solution-energie.com

© 2024 By Solution Distribution Europe the Kodak trademark, logo and trade dress are used under license from Kodak.
All right reserved. Made in China

